

# QSFP28 100GBASE 4WDM-20 Transceiver

Compliance with 4WDM MSA 4WDM-20

1310nm LAN WDM wavelength for up to 20km reach

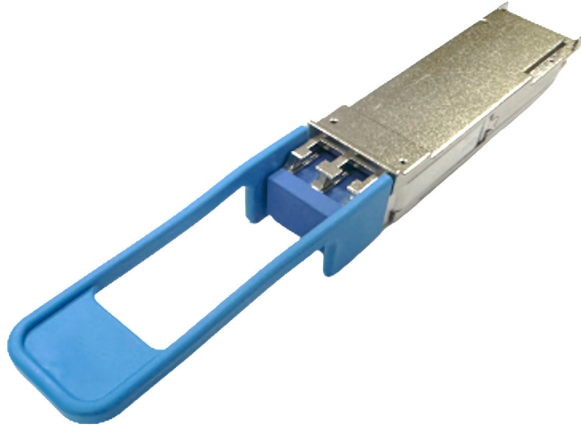

## Description

APAC QSFP28 transceiver modules are designed for use in 100 Gigabit Ethernet links on up to 20 km of single mode fiber. They are compliant with the 4WDM MSA 4WDM-20 and 100GBASE-LR4.

Digital diagnostics functions are available via the I2C interface, as specified by the QSFP28 MSA.

## Features

- Hot-pluggable QSFP28 form factor
- Power dissipation < 3.5W
- Single 3.3V power supply
- RoHS-10 Compliant (lead-free)
- Case temperature range of 0°C to +70°C
- 4x25Gbps transmitter
- 4x25Gbps retimed electrical interface
- Duplex LC receptacles
- I2C management interface
- Up to 20km reach for G.652 SMF

## Application

- 100G Ethernet
- Data Center Interconnects

## Ordering information

PART NUMBER	DISTANCE	TEMPERATURE	NOTE
LB3C-L3M-TC-N-GL	20 km	0°C to 70 °C	4X25Gbps



# QSFP28 100GBASE 4WDM-20 Transceiver

Compliance with 4WDM MSA 4WDM-20

1310nm LAN WDM wavelength for up to 20km reach

## Absolute Maximum Ratings

Not necessarily applied together. Exceeding these values may cause permanent damage. Functional operation under these conditions is not implied.

PARAMETER	SYMBOL	MIN	MAX	UNITS	NOTE
Storage Temperature	T <sub>s</sub>	-40	85	°C	
Power Supply Voltage	V <sub>cc</sub>	-0.5	3.6	V	
Relative Humidity	RH	5	85	%	

## Recommend Operating Condition

PARAMETER	SYMBOL	MIN	TYP.	MAX	UNITS	NOTE
Case Temperature	T <sub>c</sub>	0		70	°C	
Power Supply Voltage	V <sub>cc</sub>	3.14	3.3	3.46	V	
Power Dissipation	P			3.5	W	@3.3V



# QSFP28 100GBASE 4WDM-20 Transceiver

Compliance with 4WDM MSA 4WDM-20

1310nm LAN WDM wavelength for up to 20km reach

## Transmitter Optical Characteristics

$V_{cc} = 3.14\text{ V to } 3.46\text{ V}$ ,  $T_c = 0\text{ }^\circ\text{C to } 70\text{ }^\circ\text{C}$

PARAMETER	SYMBOL	MIN	TYP.	MAX	UNITS	NOTE
Operating Data Rate	<i>DR</i>		25.78125		Gbps	
Total Average Launch Power	<i>P<sub>t</sub></i>			10.5	dBm	
Average Launch Power, per Lane		-4.3		4.5	dBm	
Extinction Ratio	<i>ER</i>	4			dB	
Optical Modulation Amplitude, per lane	<i>P<sub>oma</sub></i>	-1.3		4.5	dBm	
Transmitter Dispersion Penalty, each Lane	<i>TDP</i>			2.8	dB	
Center Wavelength	<i>L0</i>	1294.53	1295.56	1296.59	nm	
	<i>L1</i>	1299.02	1300.05	1301.09	nm	
	<i>L2</i>	1303.54	1304.58	1305.63	nm	
	<i>L3</i>	1308.09	1309.14	1310.19	nm	
Side Mode Suppression	<i>SMSR</i>	30			dB	
Transmitter Reflectance	<i>RT</i>			-12	dB	
Disable Output Power	<i>P<sub>o_off</sub></i>			-30	dBm	
Output Eye Mask Definition {X1, X2, X3, Y1, Y2, Y3}			{0.25, 0.4, 0.45, 0.25, 0.28, 0.4}			

## Receiver Optical characteristics

$V_{cc} = 3.14\text{ V to } 3.46\text{ V}$ ,  $T_c = 0\text{ }^\circ\text{C to } 70\text{ }^\circ\text{C}$

PARAMETER	SYMBOL	MIN	TYP.	MAX	UNITS	NOTE
Damage Threshold, per lane	<i>P<sub>th</sub></i>	5.5			dBm	
Average power at receiver input, each lane		-14.5		4.5	dBm	
Receiver Sensitivity(OMA), per lane				-12.5	dBm	BER = 5X10 <sup>-5</sup>
Stressed Receiver Sensitivity in OMA, per lane				-10	dBm	BER = 5X10 <sup>-5</sup>
Receiver reflectance	<i>RR</i>			-26.0	dB	
LOS De-Assert	<i>LOSD</i>			-14	dBm	
LOS Assert	<i>LOSA</i>	-20			dBm	
LOS Hysteresis			0.5		dB	



# QSFP28 100GBASE 4WDM-20 Transceiver

Compliance with 4WDM MSA 4WDM-20

1310nm LAN WDM wavelength for up to 20km reach

## Electrical Characteristics

PARAMETER	SYMBOL	MIN	TYP.	MAX	UNITS	NOTE
Data Rate, per lane			25.78125		Gbps	
LP Mode/Reset/ModselL	VIL	-0.3		0.8	V	
LP Mode/Reset/ModselL	VIH	2		V <sub>cc</sub> +0.3	V	
ModPrsL/IntL	VOL	0		0.4	V	
ModPrsL/IntL	VOH	V <sub>cc</sub> -0.5		V <sub>cc</sub> +0.3	V	

## Pad assignment and Description

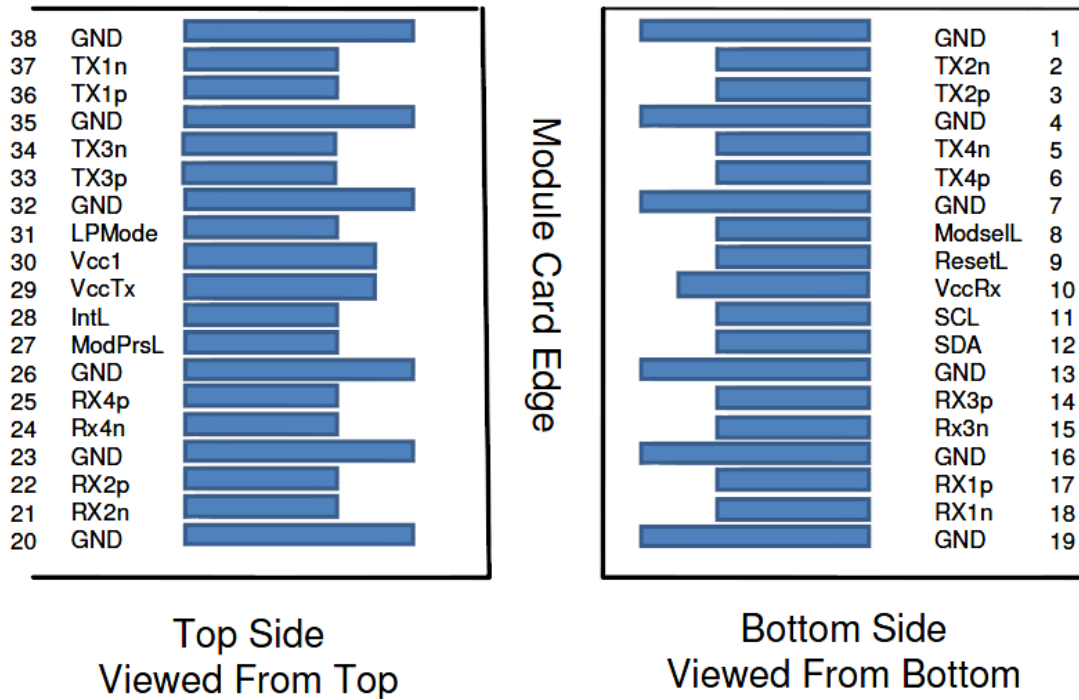

PIN	LOGIC	SYMBOL	DESCRIPTION	PLUG SEQUENCE	NOTE
1		GND	Ground	1	Note 1
2	CML-I	Tx2n	Transmitter Inverted Data Input	3	
3	CML-I	Tx2p	Transmitter Non-Inverted Data Input	3	
4		GND	Ground	1	Note 1
5	CML-I	Tx4n	Transmitter Inverted Data Input	3	
6	CML-I	Tx4p	Transmitter Non-Inverted Data Input	3	
7		GND	Ground	1	Note 1
8	LVTTL-I	ModSelL	Module Select	3	
9	LVTTL-I	ResetL	Module Reset	3	
10		Vcc Rx	+3.3V Power Supply Receiver	2	Note 2
11	LVC MOS-I/O	SCL	2-wire serial interface clock	3	
12	LVC MOS-I/O	SDA	2-wire serial interface data	3	
13		GND	Ground	1	Note 2
14	CML-O	Rx3p	Receiver Non- Inverted Data Output	3	
15	CML-O	Rx3n	Receiver Inverted Data Output	3	
16		GND	Ground	1	Note 1
17	CML-O	Rx1p	Receiver Non- Inverted Data Output	3	
18	CML-O	Rx1n	Receiver Inverted Data Output	3	
19		GND	Ground	1	Note 1
20		GND	Ground	1	Note 1



# QSFP28 100GBASE 4WDM-20 Transceiver

Compliance with 4WDM MSA 4WDM-20

1310nm LAN WDM wavelength for up to 20km reach

21	CML-O	Rx2n	Receiver Inverted Data Output	3	
22	CML-O	Rx2P	Receiver Non- Inverted Data Output	3	
23		GND	Ground	1	Note 1
24	CML-O	Rx4n	Receiver Inverted Data Output	3	
25	CML-O	Rx4p	Receiver Non- Inverted Data Output	3	
26		GND	Ground	1	Note 1
27	LVTTL-O	ModPrsL	Module Present	3	
28	LVTTL-O	IntL	Interrupt	3	
29	LVC MOS-I/O	Vcc Tx	+3.3V Power Supply transmitter	2	Note 2
30		Vcc1	+3.3V Power Supply	2	Note 2
31	LVTTL-I	LPMODE	Low Power Mode	3	
32		GND	Ground	1	Note 1
33	CML-I	Tx3p	Transmitter Non- Inverted Data Input	3	
34	CML-I	Tx3n	Transmitter Inverted Data Input	3	
35		GND	Ground	1	Note 1
36	CML-I	Tx1p	Transmitter Non- Inverted Data Input	3	
37	CML-I	Tx1n	Transmitter Inverted Data Input	3	
38		GND	Ground	1	Note 1

Note 1: GND is the symbol for signal and supply (power) common for the QSFP module. All are common within the QSFP+ module and all module voltages are referenced to this potential unless otherwise noted. Connect these directly to the host board signal-common ground plane.

Note 2: Vcc Rx, Vcc1 and Vcc Tx are the receiver and transmitter power supplies and shall be applied concurrently. Requirements defined for the host side of the Host Edge Card Connector are listed in Table. Recommended host board power supply filtering is shown in Host board power supply circuit. Vcc Rx Vcc1 and Vcc Tx may be internally connected within the QSFP module in any combination. The connector pins are each rated for a maximum current of 500 mA.

## Host board power supply circuit

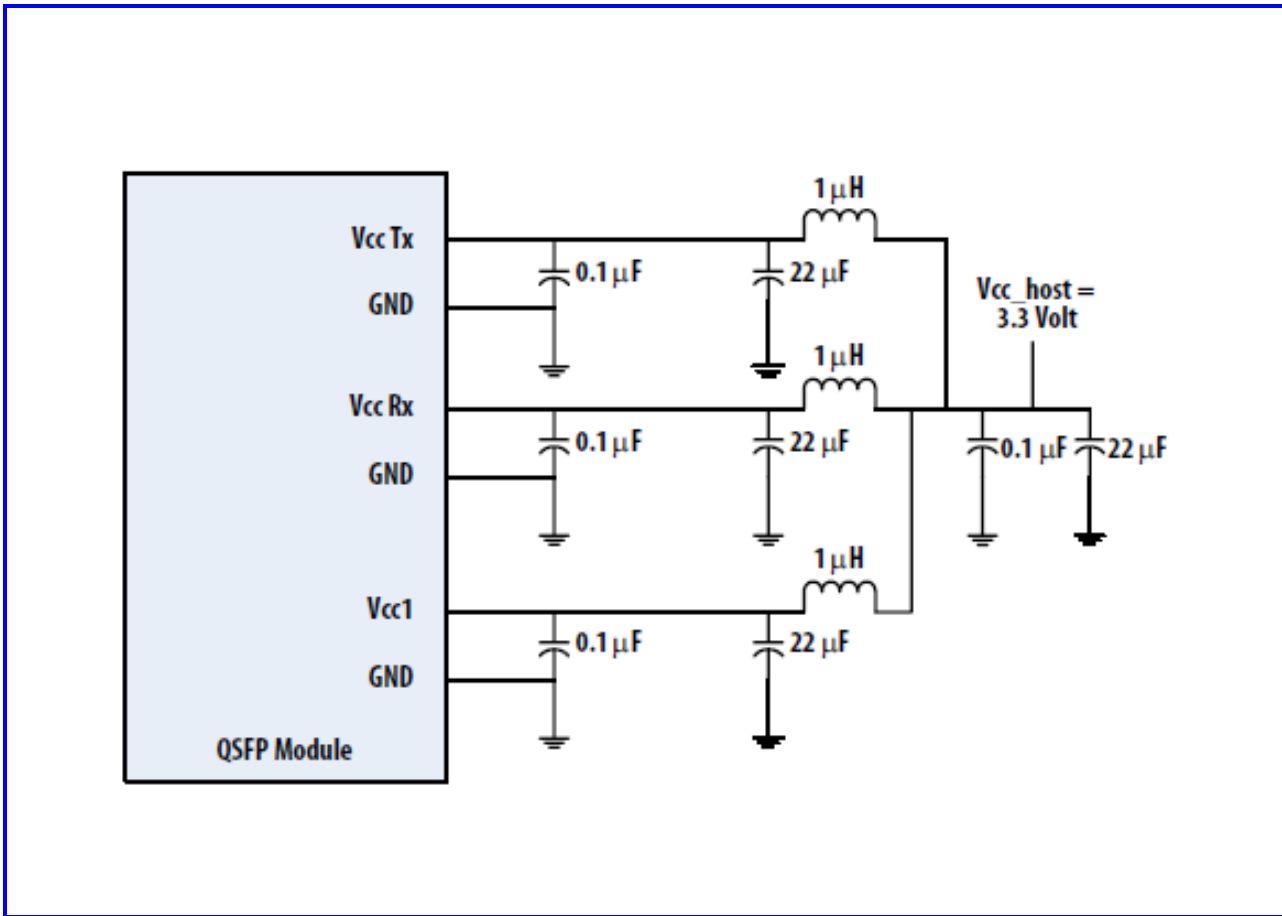

## Recommended Interface circuit

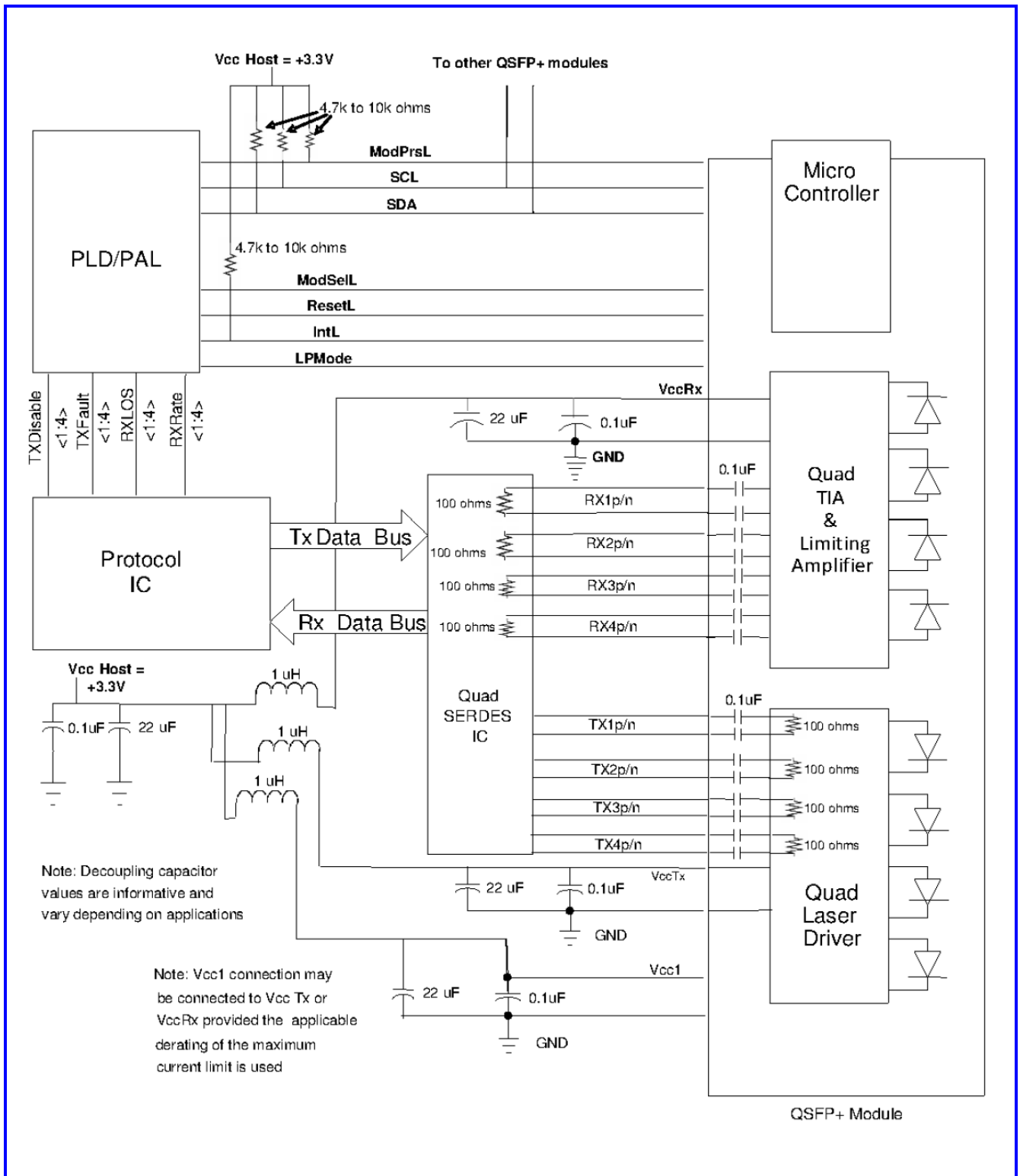



**Dimensions**

