



**RoHS Compliant**  
**TX-1310/RX-1550 nm Single-mode Bi-directional**  
**2×5 SC Simplex Connector, 3.3 V (12dB Margin)**  
**1.0625Gbd Fiber Channel/1.25 Gigabit Ethernet**



### Features

- Compliant with IEEE 802.3z Gigabit Ethernet
- Industry standard 2×5 footprint
- SC connector
- Single power supply 3.3 V
- Differential LVPECL inputs and outputs
- Compatible with solder and aqueous wash processes
- Class 1 laser product complies with EN 60825-1
- RoHS compliant

### Ordering Information

PART NUMBER	TX	RX	IN/OUT	SD	TEMPERATURE	LD TYPE
LSE2-C3S-PC-N3-BB	1310 nm	1550 nm	DC/DC	LVPECL	0 °C to 70 °C	FP
LSE2-C3S-TC-N3-BB	1310 nm	1550 nm	AC/AC	LVTTL	0 °C to 70 °C	FP
LSE2-C3S-PI-N3-BB	1310 nm	1550 nm	DC/DC	LVPECL	-40 °C to 85 °C	FP
LSE2-C3S-TI-N3-BB	1310 nm	1550 nm	AC/AC	LVTTL	-40 °C to 85 °C	FP



**RoHS Compliant**  
**TX-1310/RX-1550 nm Single-mode Bi-directional**  
**2×5 SC Simplex Connector, 3.3 V (12dB Margin)**  
**1.0625Gbd Fiber Channel/1.25 Gigabit Ethernet**

### Absolute Maximum Ratings

PARAMETER	SYMBOL	MIN	MAX	UNITS	NOTE
Storage Temperature	$T_S$	-40	85	°C	
Supply Voltage	$V_{CC}$	-0.5	4.0	V	
Input Voltage	$V_{IN}$	-0.5	$V_{CC}$	V	
Output Current	$I_o$	---	50	mA	
Operating Current	$I_{OP}$	---	400	mA	
Soldering Temperature	$T_{SOLD}$	---	260	°C	10 seconds on leads

### Operating Environment

PARAMETER	SYMBOL	MIN	MAX	UNITS	NOTE
Case Operating Temperature	$T_C$	0	70	°C	
		-40	85	°C	
Supply Voltage	$V_{CC}$	3.1	3.5	V	
Supply Current	$I_{TX} + I_{RX}$	---	250	mA	



**RoHS Compliant**  
**TX-1310/RX-1550 nm Single-mode Bi-directional**  
**2×5 SC Simplex Connector, 3.3 V (12dB Margin)**  
**1.0625Gbd Fiber Channel/1.25 Gigabit Ethernet**

**Transmitter Electro-optical Characteristics**

$V_{CC} = 3.1 \text{ V to } 3.5 \text{ V}, T_C = 0^\circ \text{C to } 70^\circ \text{C} (-40^\circ \text{C to } 85^\circ \text{C})$

PARAMETER	SYMBOL	MIN	TYP.	MAX	UNITS	NOTE
Data Rate	$B$	---	1250	1300	Mb/s	
Output Optical Power 9/125 $\mu\text{m}$ fiber	$P_{out}$	-9	---	-3	dBm	Average
Extinction Ratio	$ER$	9	---	---	dB	
Center Wavelength	$\lambda_C$	1280	1310	1355	nm	
Spectral Width (RMS)	$\Delta\lambda$	---	---	2.5	nm	
Rise/Fall Time (10–90%)	$T_{r,f}$	---	---	260	ps	
Output Eye	Compliant with IEEE802.3z					
Output power when Disabled	$P_{OFF}$			-45	dBm	Average
TX Disable Voltage-High	--	2			V	LVTTL
TX Disable Voltage-Low	--			0.8	V	LVTTL
Transmitter Data Input Voltage-High	$V_{IH} - V_{CC}$	-1.1	---	-0.74	V	DC Coupled
Transmitter Data Input Voltage-Low	$V_{IL} - V_{CC}$	-2.0	---	-1.58	V	DC Coupled
Transmitter Data Input Differential Voltage	$V_{DIFF}$	0.4	---	2.0	V	AC Coupled



**RoHS Compliant**  
**TX-1310/RX-1550 nm Single-mode Bi-directional**  
**2×5 SC Simplex Connector, 3.3 V (12dB Margin)**  
**1.0625Gbd Fiber Channel/1.25 Gigabit Ethernet**

**Receiver Electro-optical Characteristics**

$V_{CC} = 3.1\text{ V to }3.5\text{ V}$ ,  $T_C = 0\text{ }^\circ\text{C to }70\text{ }^\circ\text{C}$  ( $-40\text{ }^\circ\text{C to }85\text{ }^\circ\text{C}$ )

PARAMETER	SYMBOL	MIN	TYP.	MAX	UNITS	NOTE
Data Rate	$B$	---	1250	1300	Mb/s	
Optical Input Power-maximum	$P_{IN}$	-3	---	---	dBm	BER < $10^{-12}$
Optical Input Power-minimum (Sensitivity)	$P_{IN}$	---	---	-21	dBm	BER < $10^{-12}$
Operating Center Wavelength	$\lambda_C$	1480	---	1600	nm	
Optical isolation	$ISO$	---	---	-40	dB	$\lambda=1260\sim1360\text{nm}$
Return Loss	$RL$	---	---	-14	dB	$\lambda=1480\sim1580\text{nm}$
Signal Detect-Asserted	$P_A$	---	---	-21	dBm	Average
Signal Detect-Deasserted	$P_D$	-35	---	---	dBm	Average
Signal Detect-Hysteresis	$P_A - P_D$	1.0	---	---	dB	
Data Output Rise, Fall Time (20–80%)	$T_{r,f}$	---	---	0.35	ns	
Signal Detect Output voltage-High	$V_{OH} - V_{CC}$	-1.1	---	-0.74	V	LVPECL
Signal Detect Output voltage-Low	$V_{OL} - V_{CC}$	-2.0	---	-1.58	V	LVPECL
Signal Detect Output voltage-High	$V_{OH}$	2.4	---	$V_{CC}$	V	LVTTL
Signal Detect Output voltage-Low	$V_{OL}$	0	---	0.4	V	LVTTL
Data Output Voltage-High	$V_{OH} - V_{CC}$	-1.1	---	-0.74	V	LVPECL
Data Output Voltage-Low	$V_{OL} - V_{CC}$	-2.0	---	-1.58	V	LVPECL
Data Differential Output Voltage	$V_{DIFF}$	0.6	---	1.8	V	AC Coupled

### Block Diagram of Transceiver

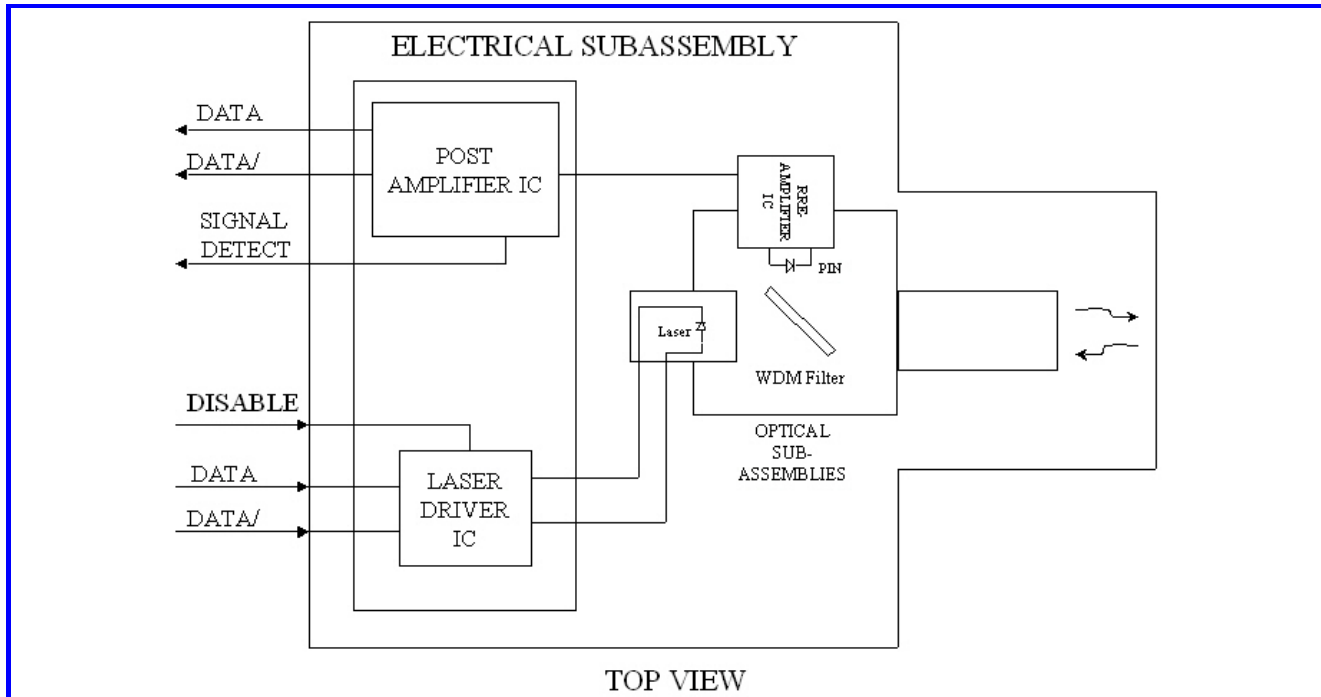

#### Transmitter and Receiver Optical Sub-assembly Section

A 1310 nm InGaAsP laser and an InGaAs PIN photodiode integrate with an WDM filter to form a bi-directional single fiber optical subassembly (OSA). The laser of OSA is driven by a LD driver IC which converts differential input LVPECL logic signals into an analog laser driving current. And, The photodiode of OSA is connected to a circuit providing post-amplification quantization, and optical signal detection.

#### Transmitter Disable

Transmitter Disable is a LVTTTL control pin. To disable the module, connect this pin to +3.3 V LVTTTL logic high "1". While, to enable module connect to LVTTTL logic low "0".

#### Receiver Signal Detect

Signal Detect is a basic fiber failure indicator. This is a single-ended LVPECL/LVTTTL output. As the input optical power is decreased, Signal Detect will switch from high to low (deassert point) somewhere between sensitivity and the no light input level. As the input optical power is increased from very low levels, Signal Detect will switch back from low to high (assert point). The assert level will be at least 1.0 dB higher than the deassert level.



**RoHS Compliant**  
**TX-1310/RX-1550 nm Single-mode Bi-directional**  
**2×5 SC Simplex Connector, 3.3 V (12dB Margin)**  
**1.0625Gbd Fiber Channel/1.25 Gigabit Ethernet**

**Connection Diagram**

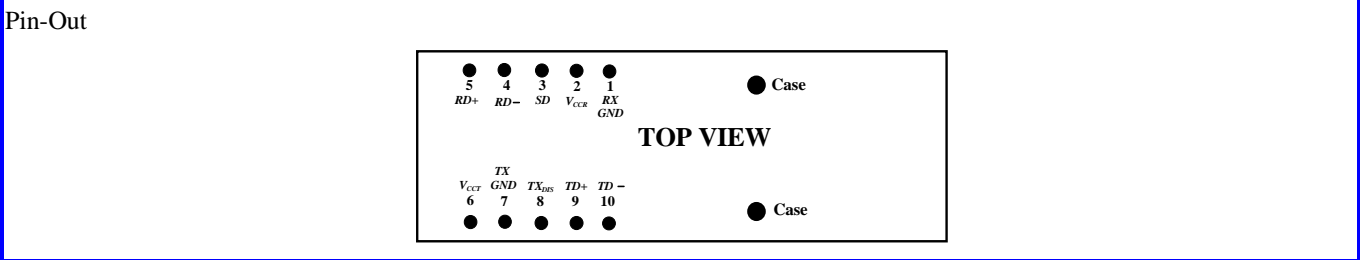

PIN	SYMBOL	DESCRIPTION
1	<i>RX GND</i>	Receiver Signal Ground, Directly connect this pin to the receiver ground plane.
2	<i>VCCR</i>	Receiver Power Supply Provide +3.3 Vdc via the recommended receiver power supply filter circuit. Locate the power supply filter circuit as close as possible to the <i>VCCR</i> pin.
3	<i>SD</i>	Signal Detect. Normal optical input levels to the receiver result in a logic “1” output, <i>V<sub>OH</sub></i> , asserted. Low input optical levels to the receiver result in a fault condition indicated by a logic “0” output <i>V<sub>OL</sub></i> , deasserted. Signal Detect is a single-ended LVPECL output. <i>SD</i> can be terminated with LVPECL techniques via 50Ω to <i>VCCR</i> – 2 V. Alternatively, <i>SD</i> can be loaded with a 180 Ω resistor to <i>RX GND</i> to conserve electrical power with small compromise to signal quality. If Signal Detect output is not used, leave it open-circuited.
4	<i>RD-</i>	<i>RD-</i> is an open-emitter output circuit. Terminate this high-speed differential LVPECL output with standard LVPECL techniques at the follow-on device input pin. (See recommended circuit schematic)
5	<i>RD+</i>	<i>RD+</i> is an open-emitter output circuit. Terminate this high-speed differential LVPECL output with standard LVPECL techniques at the follow-on device input pin. (See recommended circuit schematic)
6	<i>VCCR</i>	Transmitter Power Supply Provide +3.3 Vdc via the recommended transmitter power supply filter circuit. Locate the power supply filter circuit as close as possible to the <i>VCCR</i> pin.
7	<i>TX GND</i>	Transmitter Signal Ground Directly connect this pin to the transmitter signal ground plane. Directly connect this pin to the transmitter ground plane.
8	<i>TXDIS</i>	Transmitter Disable Connect this pin to +3.3V LVTTTL logic high “1” to disable transmitter. To enable module connect to LVTTTL logic low “0” or open.
9	<i>TD+</i>	Transmitter Data In Terminate this high-speed differential LVPECL input with standard LVPECL techniques at the transmitter input pin. (See recommended circuit schematic)
10	<i>TD-</i>	Transmitter Data In-Bar Terminate this high-speed differential LVPECL input with standard LVPECL techniques at the transmitter input pin. (See recommended circuit schematic)



**RoHS Compliant**  
**TX-1310/RX-1550 nm Single-mode Bi-directional**  
**2x5 SC Simplex Connector, 3.3 V (12dB Margin)**  
**1.0625Gbd Fiber Channel/1.25 Gigabit Ethernet**

**Recommended Circuit Schematic**

**DC/DC Coupling**

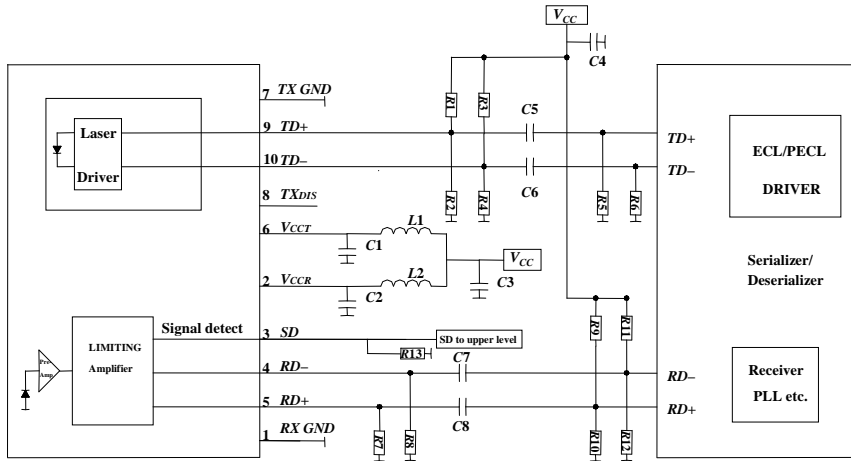

$C1/C2/C4/C5/C6/C7/C8 = 100 \text{ nF}$        $C3 = 4.7 \mu\text{F}$        $L1/L2 = 1 \mu\text{H}$   
 $R1/R3 = 82 \Omega$        $R2/R4 = 130 \Omega$        $R7/R8 = 130 \Omega$   
 $R13 = 180 \Omega \text{ (PECL)}$        $R5/R6/R9/R10/R11/R12 \text{ Depend on SerDes}$

**AC/AC Coupling**

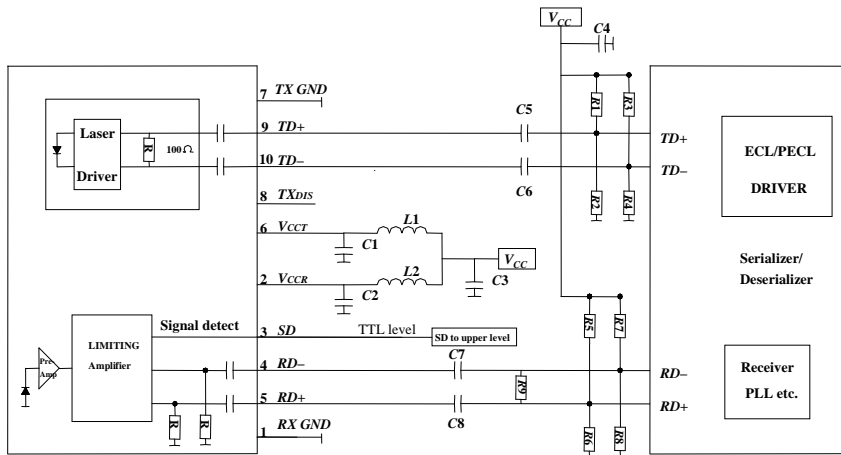

$C1/C2/C4/C5/C6/C7/C8 = 100 \text{ nF}$        $C3 = 4.7 \mu\text{F}$        $L1/L2 = 1 \mu\text{H}$   
 $R1/R2/R3/R4/R5/R6/R7/R8/R9 \text{ Depend on SerDes}$



**RoHS Compliant**  
**TX-1310/RX-1550 nm Single-mode Bi-directional**  
**2×5 SC Simplex Connector, 3.3 V (12dB Margin)**  
**1.0625Gbd Fiber Channel/1.25 Gigabit Ethernet**

---

In order to get proper functionality, a recommended circuit is provided in above recommended circuit schematic. When designing the circuit interface, there are a few fundamental guidelines to follow.

- (1) The differential data lines should be treated as 50  $\Omega$  Micro strip or strip line transmission lines. This will help to minimize the parasitic inductance and capacitance effects. Locate termination at the received signal end of the transmission line. The length of these lines should be kept short and of equal length.
- (2) For the high speed signal lines, differential signals should be used, not single-ended signals, and these differential signals need to be loaded symmetrically to prevent unbalanced currents which will cause distortion in the signal.
- (3) Multi layer plane PCB is best for distribution of  $V_{CC}$ , returning ground currents, forming transmission lines and shielding. Also, it is important to suppress noise from influencing the fiber-optic transceiver performance, especially the receiver circuit.
- (4) A separate proper power supply filter circuits shown in Figure for the transmitter and receiver sections. These filter circuits suppress  $V_{CC}$  noise over a broad frequency range, this prevents receiver sensitivity degradation due to  $V_{CC}$  noise.
- (5) Surface-mount components are recommended. Use ceramic bypass capacitors for the 0.1  $\mu\text{F}$  capacitors and a surface-mount coil inductor for 1  $\mu\text{H}$  inductor. Ferrite beads can be used to replace the coil inductors when using quieter  $V_{CC}$  supplies, but a coil inductor is recommended over a ferrite bead. All power supply components need to be placed physically next to the  $V_{CC}$  pins of the receiver and transmitter.
- (6) Use a good, uniform ground plane with a minimum number of holes to provide a low-inductance ground current return for the power supply currents.





**RoHS Compliant**  
**TX-1310/RX-1550 nm Single-mode Bi-directional**  
**2x5 SC Simplex Connector, 3.3 V (12dB Margin)**  
**1.0625Gbd Fiber Channel/1.25 Gigabit Ethernet**

### Recommended Board Layout Hole Pattern

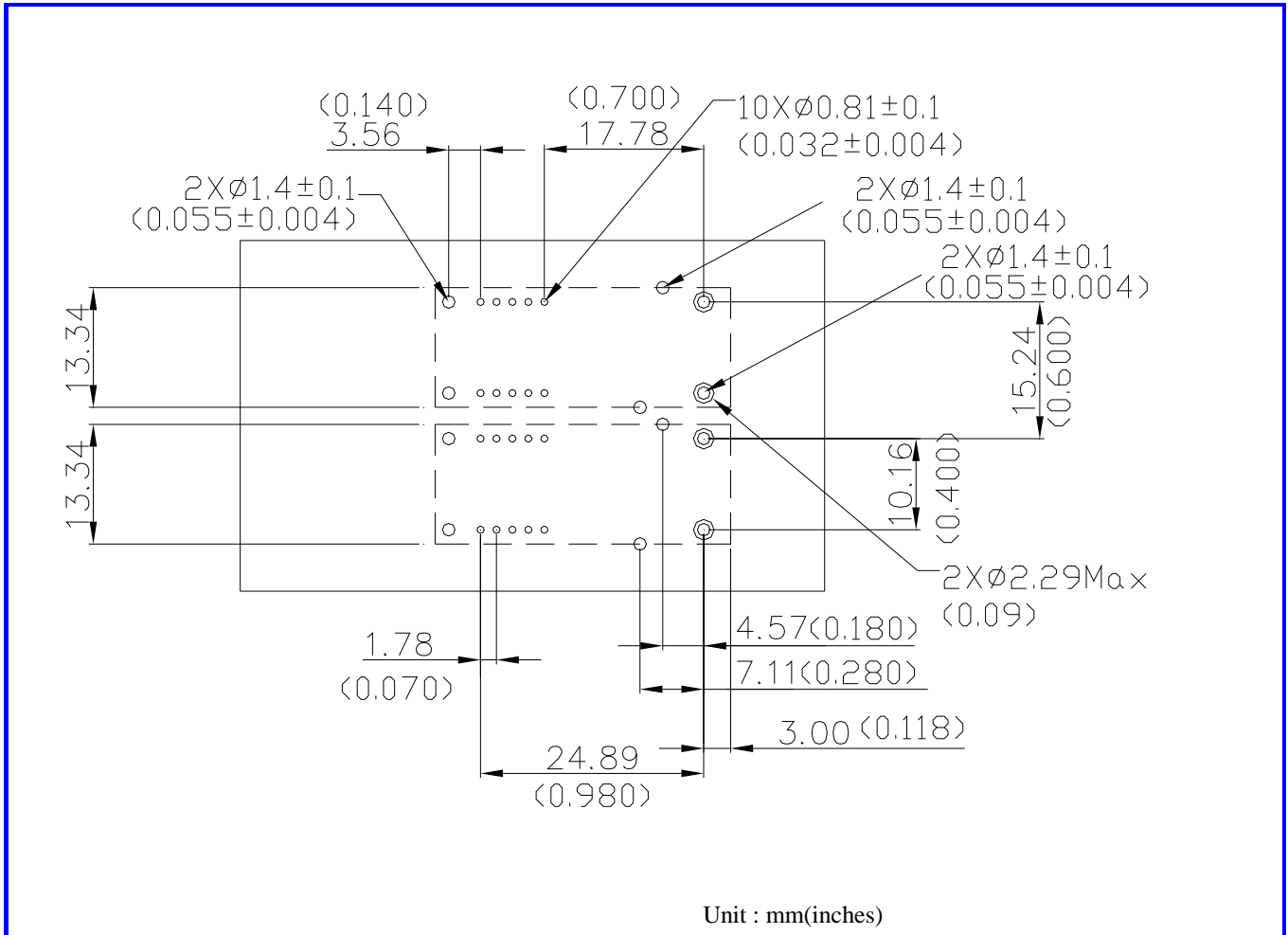

This transceiver is compatible with industry standard wave or hand solder processes. After wash process, all moisture must be completely remove from the module. The transceiver is supplied with a process plug to prevent contamination during wave solder and aqueous rinse as well as during handling, shipping or storage.

Solder fluxes should be water-soluble, organic solder fluxes. Recommended cleaning and degreasing chemicals for these transceivers are alcohol's (methyl, isopropyl, isobutyl), aliphatics (hexane, heptane) and other chemicals, such as soap solution or naphtha. Do not use partially halogenated hydrocarbons for cleaning/degreasing.



RoHS Compliant  
TX-1310/RX-1550 nm Single-mode Bi-directional  
2x5 SC Simplex Connector, 3.3 V (12dB Margin)  
1.0625Gbd Fiber Channel/1.25 Gigabit Ethernet

### Drawing Dimensions

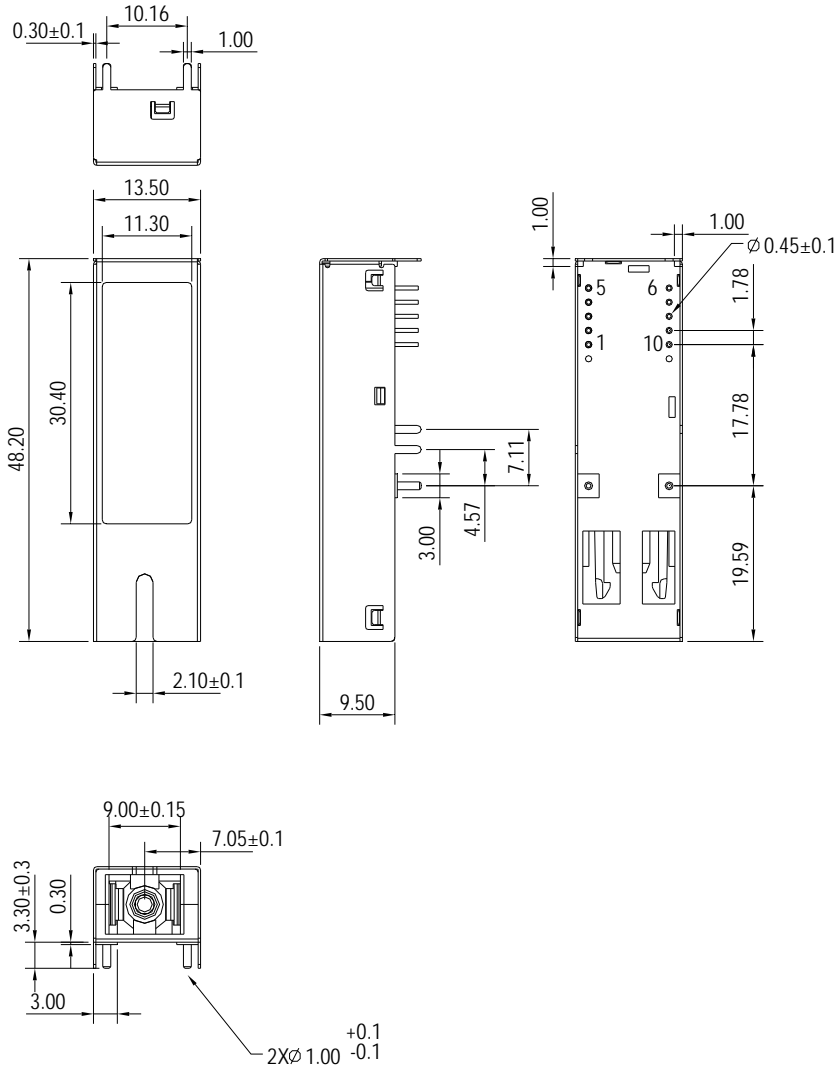

ALL DIMENSIONS ARE  $\pm 0.20$ mm UNLESS OTHERWISE SPECIFIED  
Unit : mm

### Optical Receptacle Cleaning Recommendations

All fiber stubs inside the receptacle portions were cleaned before shipment. In the event of contamination of the optical ports, the recommended cleaning process is the use of forced nitrogen. If contamination is thought to have remained, the optical ports can be cleaned using a NTT international Cletop® stick type and HFE7100 cleaning fluid. Before the mating of patchcord, the fiber end should be cleaned up by using Cletop® cleaning cassette.

#### Cleaning of patchcord



#### Cleaning of fiber stub

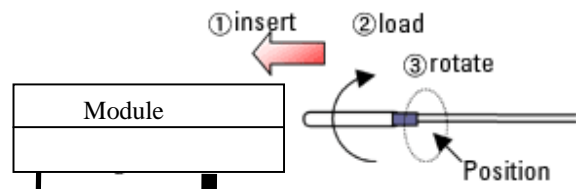

1. Insert  
Ensure that stick is held straight when inserting into sleeve.
2. Load  
Apply sufficient pressure (approx 600-700g) to ensure ferrule a little depressed in sleeve.
3. Rotate  
Rotate stick clockwise 4-5 times, while ensuring direct contact with ferrule end-face is maintained.

*Notice: Number of possible wipes: Maintenance (repair)  
 ~1 use / piece  
 Equipment construction: 4 uses / piece (max.)*

Note: The pictures were extracted from NTT-ME website. And the Cletop® is a trademark registered by NTT-ME



**RoHS Compliant**  
**TX-1310/RX-1550 nm Single-mode Bi-directional**  
**2×5 SC Simplex Connector, 3.3 V (12dB Margin)**  
**1.0625Gbd Fiber Channel/1.25 Gigabit Ethernet**

---

### Eye Safety Mark

The LSE series Single mode transceiver is a class 1 laser product. It complies with EN 60825-1 and FDA 21 CFR 1040.10 and 1040.11. In order to meet laser safety requirements the transceiver shall be operated within the Absolute Maximum Ratings.

#### Caution

**All adjustments have been done at the factory before the shipment of the devices. No maintenance and user serviceable part is required. Tampering with and modifying the performance of the device will result in voided product warranty.**

#### Required Mark

Class 1 Laser Product  
Complies with  
21 CFR 1040.10 and 1040.11

Note : All information contained in this document is subject to change without notice.